

TB8100 base station

Remotely Monitoring and Configuring the TB8100 Base Station



Application Note TN-742
1 September 2006

Contents

- 1 **Site Planning** 4
- 2 **Setting up on the Bench** 5
 - 2.1 Essential Modem Features 5
 - 2.2 Base Station to Modem Connection 5
 - 2.3 Alarm Center PC to Modem Connection 10
 - 2.4 Service Kit PC to Modem Connection 12
- 3 **Preparing for Installation at Site** 12
- 4 **At Site** 12

Document Conventions

‘Configure > Communications > Alarm Center’ means ‘click the Configure icon on the toolbar, then in the navigation pane find the Communications group, and select Alarm Center from it’.

Associated Documentation

- TN-906: Connecting to TB8100 Base Stations via an Asynchronous Port Switch
- TN-1142-AN: Connecting to a TB8100 via Ethernet.
- TB8100 Installation and Operation Manual
- TB8100 Service Kit and Alarm Center User’s Manuals and online Help

This Application Note provides information on how to install and set up modem communications for a system of TB8100 base stations. It is intended for system designers and integrators. Modem communications allow remote monitoring, configuration, and firmware upgrade using the Service Kit and remote alarm monitoring using an Alarm Center. For more detail or answers to specific questions, consult the documentation for the TB8100 base station and Service Kit or contact your nearest Tait Dealer or Customer Service Organisation.

Alternatively, TB8100 base stations can be remotely monitored, configured, and upgraded via an Ethernet connection. See TN-1142 for details.

Figure 1 shows a small example system. Each base station has a modem link and can dial the Alarm Center when an alarm occurs. The Alarm Center PC is set up to use its modem to send emails via an ISP.

Figure 1 Example System

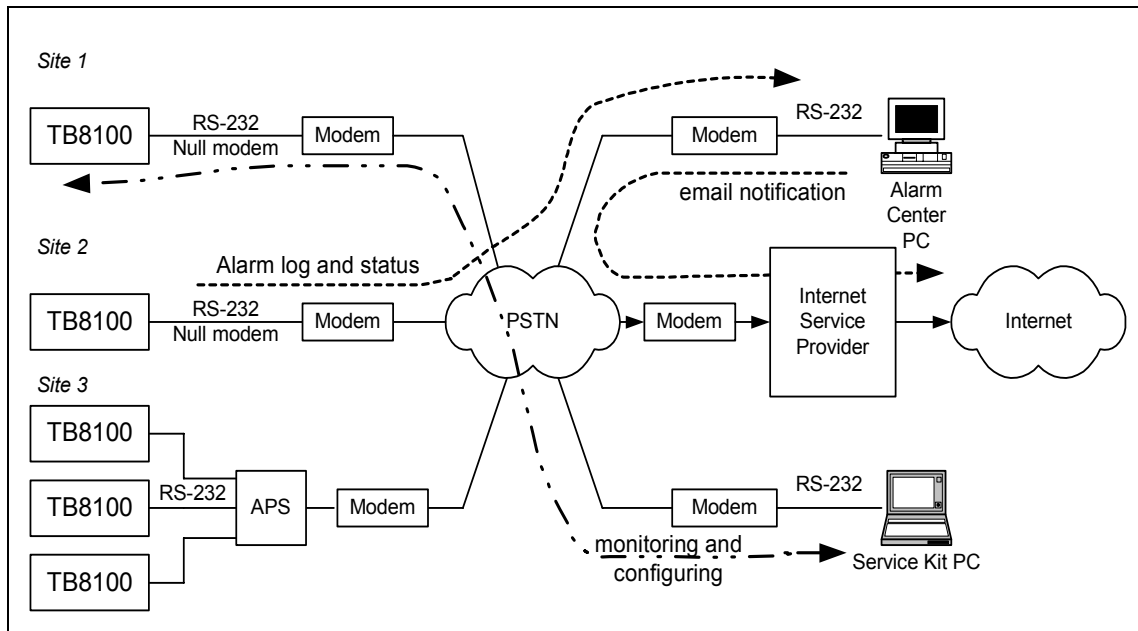

Here's how communications might proceed in a typical scenario when an alarm occurs and the technician responds:

1. An alarm occurs at one of the base stations. In response, the Task Manager action 'email status now' instructs the TB8100 to dial the Alarm Center and send the alarm log and the current status of base station alarms.
2. The Alarm Center adds the new alarm to its log.
3. The Alarm Center forms the alarm log and status information into an email and sends it via an ISP to the address(es) provided by the base station. It can use a dial-up or a LAN connection, depending on the PC's configuration.

4. The maintenance technician receives the e-mail over the Internet.
5. The maintenance technician can now use the TB8100 Service Kit software to remotely connect and log on to the TB8100. This connection uses the same modem at the site. Now the technician can use the full capabilities of the Service Kit to monitor the base station, carry out diagnostic tests, and make configuration changes.

1 Site Planning

Remote sites require careful planning and implementation. The following issues are worth thinking through prior to installation to reduce potentially expensive trips back to site:

Issue	Suggestion
What types of power are available at the remote site (AC, DC only, Generator, Batteries, Solar)	Will the modem run from the available power or does it need a converter of some kind (AC-DC, DC-DC). Consider using the TB8100's auxiliary power output if the modem can operate on DC power.
What happens if the Power for the site fails, is there a backup supply (generator)? How is this switched in (manual/automatic)?	Before installation, test that the modem can operate on both normal power and generator power. Consider installing surge protection and smoothing equipment.
What type of modem are you going to use at site?	For remote sites, industrial modems are recommended as they are designed to be more rugged and cope better with temperature variations and power fluctuations. They also typically have more robust watch-dog timers that reset them in case of software error, so that you don't need to visit the site to switch the modem off and back on again.
Where will the modem be mounted at site?	Consider heat and other factors like dust and humidity. Also the length of communications cables available.
Is there more than one Base Station to be monitored at site?	If there is only one telephone line available, consider using an Asynchronous Port Switch (APS) to enable the Service Kit to dial individual base stations. The APS and the modems should be powered from the same source. Refer to TN-906 for more details.
Is your base station fitted with a TaitNet RS-232 system interface board?	If your base station is fitted with a TaitNet RS-232 system interface board, the modem can be connected to the RS-232 port at the rear of the base station. The RS-232 port on the control panel is disabled.
How many sites are to be monitored?	Do you need different connection scenarios for each or can you use a standard solution?
How many alarms do you want to receive?	Define Task Manager tasks only for the alarms you want to know about.
What can you do if there is no telephone line to a base station site?	Consider using radio modems. If the base station needs to dial out to an alarm center, the modems must support the Hayes AT command set. Otherwise, almost any radio modem that provides a transparent point-to-point link can be used.

2 Setting up on the Bench

It is best to set up the equipment on the bench, configure it, and verify that it works before installing it on site. This application note assumes that the equipment is being set up and tested on a bench before being installed.

2.1 Essential Modem Features

The ATX0 command **must** be available in any modem which is used with the base station, Service Kit, or Alarm Center. This command limits the result codes to 0-4, i.e:

- 0 – OK
- 1 – connect
- 2 – ring
- 3 – no carrier
- 4 – error



Note Some modems will include result code 8 (no answer) in the list for ATX0. This is also acceptable.

2.2 Base Station to Modem Connection

If the base station will dial an Alarm Center, the modem is configured by configuring the base station using the Service Kit. If not, use a terminal program to configure the modem.

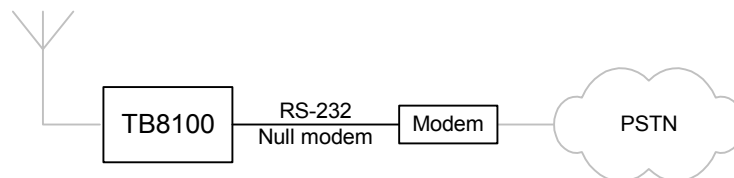

Important You must save all modem configuration strings into internal NVRAM using the appropriate AT commands. This will ensure the modem is correctly configured after a power-up/reset.



Important Check the documentation that applies to your modem to make sure the modem commands used in this TN match the commands needed to carry out the required task. Some AT commands are implemented differently in some modems.

Equipment Required

- PC
- Base Station (with an Alarm Reporting license if you want it to communicate with an Alarm Center and possibly also with an Advanced Profiles and Task Manager license if a total of more than 20 tasks are needed)
- Modem (for the base station)
- Two phone lines
- Straight through cable: DE9 (female) to DE9 (male)
- Null modem cable: DE9 (male) to DE9/DB25 (male)

A null modem cable is **NOT** the same as the cable normally distributed with a modem. The configuration and pin allocations for a null modem cable are shown in [Figure 2](#).



Note Some external modems use a DB25 connector, others a DE9 connector. Obtain the appropriate cable/converter for your setup.

Figure 2 Null Modem Cable Configuration

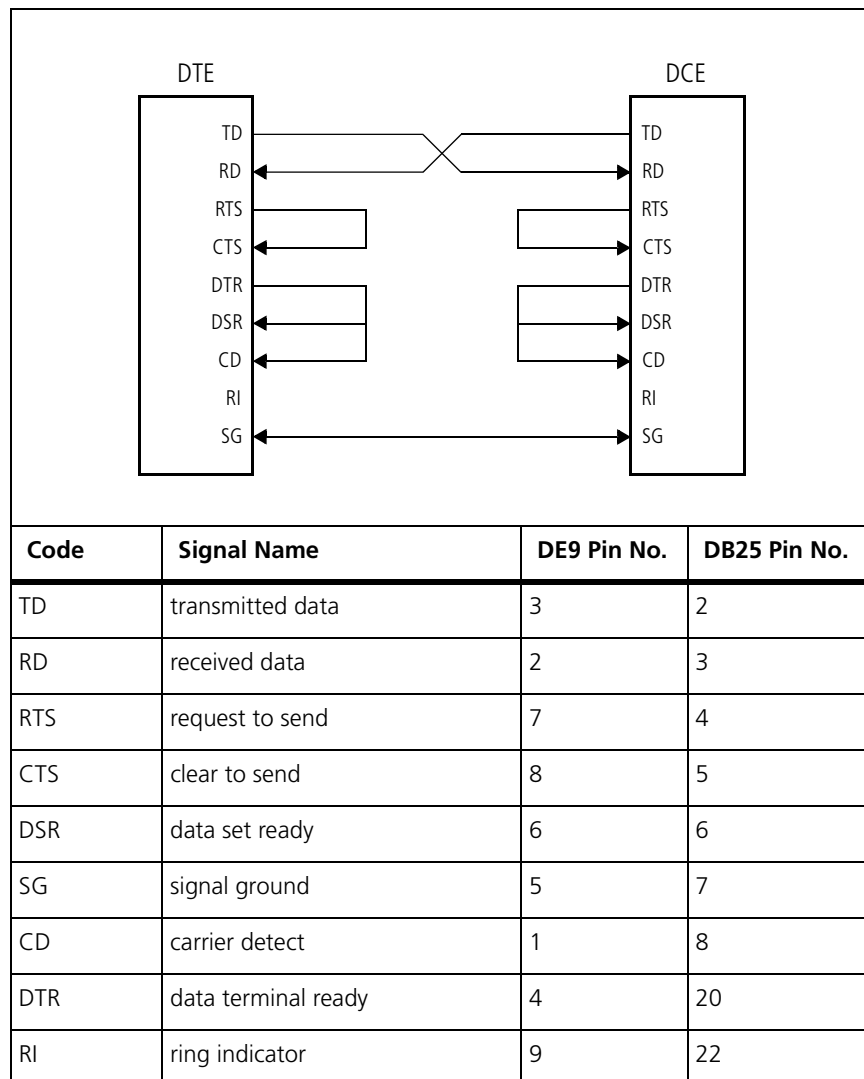

Configuring the Base Station Modem

Follow these instructions to configure the modem which will be connected to the base station. You will need to carry out these instructions whenever the modem is replaced or if the 'restore factory defaults' Hayes AT command (AT&F0) is used.

1. Connect the modem to one of the PC's COM ports using a straight through cable.
2. Open a terminal program (such as HyperTerminal) and configure the communications settings to:
 - data bits - 8
 - stop bit - 1
 - parity - none
 - baud rate - set to the speed you want the modem to use. Speeds in the range 57,600 to 9,600 Baud are supported. Tait recommends that you use the worst speed that you expect from the modem-to-modem link. The choice of speed is important because the base station does not have flow control. This can cause problems when reading large configurations files over slow links.
3. Connect to the modem and type 'AT'. This should return 'OK' or 'O'.
4. The modem needs to be configured so that the base station will understand responses from the modem correctly, so complete the following:
 - AT&F0 [Enter] *(Reset the modem to factory defaults)*
 - ATV0 [Enter] *(Enable numeric responses to the base station)*
 - ATE0 [Enter] *(Disable the modem's echo feature)*
 - ATX0 [Enter] *(Report basic call progress result codes)*
 - AT&D0 [Enter] *(Ignore the DTR line - assume it is always on)*
 - AT&K0 [Enter] *(Disable flow control between the modem and the BS)*
5. If the modem is also to auto-answer remote log-in requests from the Service Kit, enter the following:
 - ATS0=3 [Enter] *(Auto-answer 'On' and set to pick up after 3 rings)*
6. Save the new configuration so it is used from power-up:
 - AT&Y0&W0 [Enter] *(Save the configuration and start up on it at power-up)*



Note It is possible to do all these commands at once by entering AT&F0V0E0X0&K0&D0&Y0&W0.

7. If the modem supports the command AT&B1, enter AT&B1&W0. This stores the modem's current serial baud rate, which is the value you specified above in step 2. This baud rate will be adopted after a reset or power cycle.



Note Steps 7. and 9. are not necessary if the base station connects via an APS, provided that the APS configures the modem on power-up.

8. Use the Service Kit (Configure > Communications > Alarm Center) to set the speed that the base station uses when dialling out to an Alarm Center to the same speed as you set the modem.



Tip Check that the Service Kit status bar displays the baud rate that you set the base station's modem to. (The status bar displays the remote modem-to-base station baud rate, not the overall communication speed.)

9. If you cannot fix the modem's baud rate, use the following work-around to keep the modem using the desired baud rate.
 - a. Set up a Task Manager timer 'dial-out.' Its duration needs to be short enough (for example, 24 hours) to reduce the risk of communication problems caused by the modem reverting to its default baud rate after a reset.
 - b. Set up Task Manager statements that cause the base station to periodically dial out to the alarm center (or to a dummy telephone number if there is no alarm center). For example:

IF Base station in Run mode THEN Start timer (dial-out)

IF Timer expired (dial-out) THEN Send alarm log now

IF Timer expired (dial-out) THEN Start timer (dial-out)

This will cause the modem to adopt the baud rate configured in the base station.

Configuring the Base Station for Alarm Center and Remote Service Kit Operation

Follow these instructions if the remote connection will be used by the Service Kit to dial the base station, and by the base station to dial the Alarm Center.

1. Install the Service Kit on the PC.
2. Power up the base station and connect the serial port on the control panel to the PC's available serial port using the straight through cable supplied.
3. Load the Service Kit and connect to the base station using the direct connection configured for the serial port you used.
4. Read the base station's configuration.
5. Select Configure > Communications > Alarm Center.

6. In the Alarm Center form, enable the Alarm Center connection and fill in the details (use the on-line help system if required).

7. Make sure that the default modem command string suits your modem and system. 'AT&D0E0V0X0&K0' has the following meaning:
 - &D0 *(Ignore the DTR line - assume it is always on)*
 - E0 *(Disable the modem's echo feature)*
 - V0 *(Enable numeric responses to the base station)*
 - X0 *(Report basic call progress result codes)*
 - &K0 *(disables flow control between the modem and the BS.)*
8. Under Connection timing, make sure that you have a sufficient number of retries and that the minimum interval is long enough to stop the base station unnecessarily blocking other base station's access to the Alarm Center, but short enough to give prompt notification of faults.
9. If you also want email notification, select Configure > Communications > Email.
10. Enable email and fill in the details (use the on-line help system).

11. Select Configure > Base Station >Task Manager and add suitable tasks that configure the notification of alarms. For example:
IF Base station alarm on THEN Send alarm log now
 OR:
IF Base station alarm on THEN Email status now
12. Save the configuration then program it into the Base Station.
13. Connect the modem to the Base Station using the null modem cable.
14. Use a phone to ring the modem's number and check that it answers after three rings and attempts to make a connection.

2.3 Alarm Center PC to Modem Connection

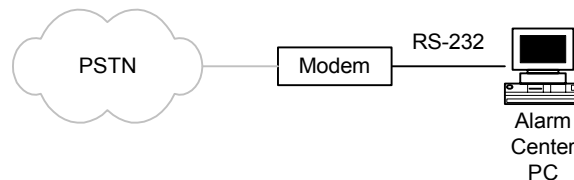

Configuring the Alarm Center Modem

Follow these instructions if the modem will be connected to an Alarm Center and will answer incoming emails.

1. Connect the modem to one of the PC's COM ports using a straight through cable.
2. Open a terminal program (HyperTerminal or similar) and configure the communications settings to:
 - data bits - 8
 - stop bit - 1
 - parity - none
 - baud rate - 115200.
3. Connect to the modem and type 'AT'. This should return 'OK' or '0'.
4. Configure the modem as follows:
 - AT&F0 [Enter] *(Reset the modem to factory defaults)*
 - ATE0 [Enter] *(Disable the modem's echo feature)*
 - ATV1 [Enter] *(Word responses)*
 - ATX4 [Enter] *(All response and dial tone and busy signal detection)*
 - ATL0 [Enter] *(Low speaker volume)*
 - ATS0=0 [Enter] *(Auto-answer 'Off'; the Alarm Center will answer when required)*

5. If the user does not want the speaker left on, use the following command:
ATM0 [Enter] *(Internal speaker 'Off')*
6. Save the configuration so it is used from power-up:
AT&Y0&W0 [Enter] *(Save the configuration and start up on it at power-up)*

Each command should return 'OK' (word response) or '0' (numeric response). If it doesn't, check the modem's manual to see if the command is supported.

7. Close the terminal program and start the Alarm Center.
8. Use a phone to ring the modem's number and check that it answers after three rings and attempts to make a connection.
9. Have the base station send an alarm message to the Alarm Center. Check that the Alarm Center receives and processes it correctly.

Configuring the Alarm Center PC

1. Install the modem software drivers following the manufacturer's instructions (either an external or internal modem is suitable).
2. Connect the modem to the PC and to a telephone line, using the cables provided with the modem.
3. Select Start > Programs > Tait Programming Applications > TB8100 Alarm Center.
4. Configure the Alarm Center to use the modem installed (use the online Help if required).
5. Set up the PC's Internet settings (Control Panel > Internet Options > Settings tab). Please refer to your Windows documentation for instructions. The Alarm Center can connect to an ISP via dial-up or via a LAN connection.
6. Verify that the Alarm Center is operating by using a phone to call the Alarm Center. It should pick up after a few rings and attempt to make a connection.
7. Get a base station to send a test email (Diagnose > Reciter > Misc I/O) to check the communications path.
8. Confirm that the email was received.

2.4 Service Kit PC to Modem Connection

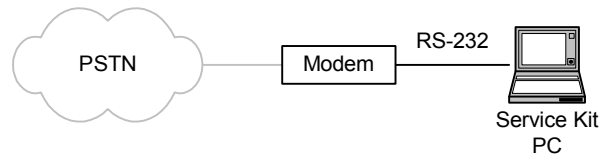

1. In the Service Kit PC, install the modem software drivers following the manufacturer's instructions (either an external or internal modem is suitable).
2. Run the Service Kit, select File > Configure Connections and use the New button to set up modem dialup connections for each base station system. Make sure that you enter the correct phone number.
3. Using these connections, connect and log on to each base station in turn. Verify that the Base Station information can be viewed over the modem link.

3 Preparing for Installation at Site

1. If the Alarm Center's permanent phone number is different to the one you used when setting up on the bench, connect the Service Kit PC to the base station. Using the modem connection or a direct connection, program the base station with the correct Base Station dial out phone number (under Configuration > Communications > Alarm Center).
2. Set up the Alarm Center before installing any sites. This way you can verify each site is dialing and getting an answer before continuing.

4 At Site

1. Install the equipment, making sure that you have a null modem cable between the modem and the base station.
2. If you have a laptop with an internal modem, verify modem operation by dialing the phone number of the Base Station (otherwise, use a phone to verify that the modem is at least answering).
3. Verify alarm dial-out by generating an alarm and verifying that the modem is used to dial the Alarm Center PC (if possible, have a colleague available to confirm that the email or the alarm log arrives).

Tait Contact Information

**Corporate Head
Office
New Zealand**

Tait Electronics Limited
P.O. Box 1645
Christchurch
New Zealand

For the address and telephone number of regional offices, refer to the
TaitWorld website:

Website: <http://www.taitworld.com>

Technical Support

For assistance with specific technical issues, contact Technical Support:

E-mail: support@taitworld.com

Website: <http://support.taitworld.com>